

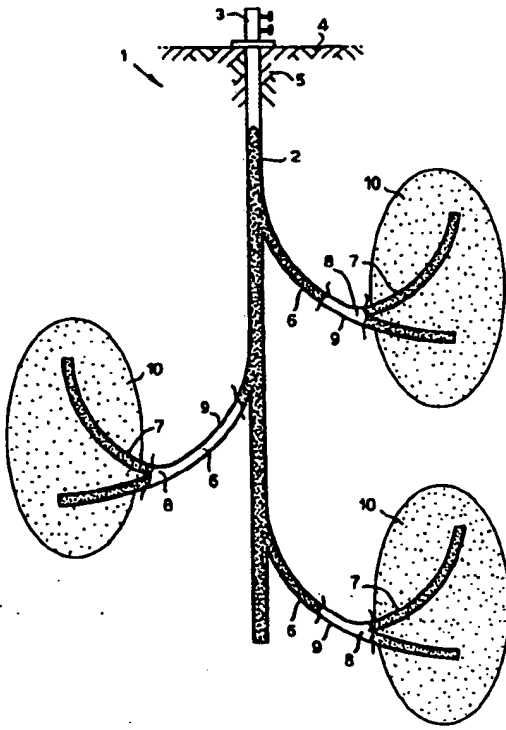

INTERNATIONAL APPLICATION PUBLISHED UNDER THE PATENT COOPERATION TREATY (PCT)

(51) International Patent Classification ⁷ : E21B 43/10	A1	(11) International Publication Number: WO 00/46484
		(43) International Publication Date: 10 August 2000 (10.08.00)
(21) International Application Number: PCT/EPO00/00791	(81) Designated States: AE, AL, AM, AT, AU, AZ, BA, BB, BG, BR, BY, CA, CH, CN, CR, CU, CZ, DE, DK, DM, EE, ES, FI, GB, GD, GE, GH, GM, HR, HU, ID, IL, IN, IS, JP, KE, KG, KP, KR, KZ, LC, LK, LR, LS, LT, LU, LV, MA, MD, MG, MK, MN, MW, MX, NO, NZ, PL, PT, RO, RU, SD, SE, SG, SI, SK, SL, TJ, TM, TR, TT, TZ, UA, UG, UZ, VN, YU, ZA, ZW, ARIPO patent (GH, GM, KE, LS, MW, SD, SL, SZ, TZ, UG, ZW), Eurasian patent (AM, AZ, BY, KG, KZ, MD, RU, TJ, TM), European patent (AT, BE, CH, CY, DE, DK, ES, FI, FR, GB, GR, IE, IT, LU, MC, NL, PT, SE), OAPI patent (BF, BJ, CF, CG, CI, CM, GA, GN, GW, ML, MR, NE, SN, TD, TG).	
(22) International Filing Date: 1 February 2000 (01.02.00)		
(30) Priority Data: 99300717.8 1 February 1999 (01.02.99) EP		
(71) Applicant (for all designated States except CA): SHELL INTERNATIONALE RESEARCH MAATSCHAPPIJ B.V. (NL/NL); Carel Van Bylandtlaan 30, NL-2596 HR The Hague (NL).		
(71) Applicant (for CA only): SHELL CANADA LIMITED [CA/CA]; 400 - 4th Avenue S.W., Calgary, Alberta T2P 2H5 (CA).	<p>Published With international search report. Before the expiration of the time limit for amending the claims and to be republished in the event of the receipt of amendments.</p>	
(72) Inventors: VAN BUREN, Markus, Antonius; PDO Office, Mina Al Fahal, 113 Muscat (OM). SUREWAARD, Johannes, Henricus, Gerardus; PDO Office, Mina Al Fahal, 113 Muscat (OM).		
(54) Title: METHOD FOR CREATING SECONDARY SIDETRACKS IN A WELL SYSTEM		
(57) Abstract		
<p>A method is disclosed for creating one or more secondary sidetracks in an oil and/or gas well assembly which comprises a primary wellbore (2) and one or more primary sidetracks (6) so that a root-like multilateral well structure is created. The method makes use of an expandable well liner (9) in the primary sidetracks (6) so as to create a liner having a sufficient internal width to allow sidetracking equipment to be inserted and operated in the primary sidetrack to drill and complete the secondary sidetracks (7).</p> 		

FOR THE PURPOSES OF INFORMATION ONLY

Codes used to identify States party to the PCT on the front pages of pamphlets publishing international applications under the PCT.

AL	Albania	ES	Spain	LS	Lesotho	SI	Slovenia
AM	Armenia	FI	Finland	LT	Lithuania	SK	Slovakia
AT	Austria	FR	France	LU	Luxembourg	SN	Senegal
AU	Australia	GA	Gabon	LV	Latvia	SZ	Swaziland
AZ	Azerbaijan	GB	United Kingdom	MC	Monaco	TD	Chad
BA	Bosnia and Herzegovina	GE	Georgia	MD	Republic of Moldova	TG	Togo
BB	Barbados	GH	Ghana	MG	Madagascar	TJ	Tajikistan
BE	Belgium	GN	Guinea	MK	The former Yugoslav Republic of Macedonia	TM	Turkmenistan
BF	Burkina Faso	GR	Greece	ML	Mali	TR	Turkey
BG	Bulgaria	HU	Hungary	MN	Mongolia	TT	Trinidad and Tobago
BJ	Benin	IE	Ireland	MR	Mauritania	UA	Ukraine
BR	Brazil	IL	Israel	MW	Malawi	UG	Uganda
BY	Belarus	IS	Iceland	MX	Mexico	US	United States of America
CA	Canada	IT	Italy	NE	Niger	UZ	Uzbekistan
CF	Central African Republic	JP	Japan	NL	Netherlands	VN	Viet Nam
CG	Congo	KE	Kenya	NO	Norway	YU	Yugoslavia
CH	Switzerland	KG	Kyrgyzstan	NZ	New Zealand	ZW	Zimbabwe
CI	Côte d'Ivoire	KP	Democratic People's Republic of Korea	PL	Poland		
CM	Cameroon	KR	Republic of Korea	PT	Portugal		
CN	China	KZ	Kazakhstan	RO	Romania		
CU	Cuba	LC	Saint Lucia	RU	Russian Federation		
CZ	Czech Republic	LJ	Liechtenstein	SD	Sudan		
DE	Germany	LK	Sri Lanka	SE	Sweden		
DK	Denmark	LR	Liberia	SG	Singapore		
EE	Estonia						

METHOD FOR CREATING SECONDARY SIDETRACKS IN A WELL SYSTEM

Background of the Invention

5 The invention relates to a method for creating secondary sidetracks in a well system which comprises a main wellbore into which one or more primary sidetracks debouch.

Such a well system is known from International patent application WO 98/49424.

10 A difficulty which arises with such a well system is that conventional wells have a telescoping nature which stems from the fact that a casing is inserted into the main well at various stages of the drilling process and casing sections which are inserted thereafter need to have a smaller outer diameter than the inner diameter of the previously installed casing sections, and that the
 15 liner which is subsequently inserted into the primary sidetrack needs to have an outer diameter which is significantly smaller than the inner diameter of the casing of the main wellbore at the branchpoint in order to allow a smooth insertion of the liner from the main
 20 wellbore into the primary sidetrack.

As a result the liner of the primary sidetrack has such a small diameter that it is hardly feasible and economically unattractive to drill secondary sidetracks away from the primary sidetrack.

25 An object of the present invention is to provide a method for creating one or more secondary sidetracks in a well system in an efficient and economical manner.

Summary of the Invention

30 In accordance with the present invention a method is provided for creating a secondary sidetrack in a well system for production of hydrocarbon fluids which

comprises a main wellbore and a primary sidetrack which debouches into the primary wellbore, the method comprising:

- 5 - inserting an unexpanded expandable liner into the primary sidetrack;
- radially expanding the liner;
- creating an opening in the wall of the expanded liner; and
- 10 - drilling a secondary sidetrack into the hydrocarbon formation through said opening.

Preferably the expandable liner is a steel liner which is expanded by pushing or pulling an expansion mandrel which is provided with a conical wear-resistant outer surface and/or rollers through the liner.

15 The expanded liner has an internal diameter which is sufficiently large to allow drilling and/or kick off equipment to be inserted into the primary sidetrack for drilling of one or more secondary sidetrack, which also have an internal width which is sufficiently large to
20 serve as a wellbranch through which hydrocarbon fluids can flow into the well system.

Hence the method according to the invention allows to create a root-like well system which provides an optimal drainage of hydrocarbon fluids from a hydrocarbon bearing formation, even if the formation has a low permeability.
25

In an attractive embodiment of the method according to the invention the expandable liner is formed by a coiled tubing through which drilling fluid is pumped towards a downhole drilling assembly which is used to
30 drill the primary sidetrack and which coiled tubing is radially expanded after the primary sidetrack has been drilled.

Also the secondary sidetrack may be drilled using a coiled tubing which is expanded to form an expanded liner
35 after completion of the drilling activities.

Alternatively the secondary sidetrack may be lined using an expandable slotted liner of which the slots are staggered and open up into diamond shaped apertures upon expansion of the liner. Such an expandable slotted line
5 is known from US patent No. 5,366,012. Such a slotted liner may be surrounded in the inflow region of the secondary sidetrack by an expandable sandscreen, such as a sandscreen which is disclosed in International patent application PCT/EP96/04887.

10 In stable reservoir formations the secondary sidetrack may be an open uncased hole whereas if the reservoir formation is very unstable the secondary sidetrack may be lined with an initially unslotted expanded or unexpanded liner into which perforations are
15 shot using a perforation gun which is known per se.

The invention also relates to a root-like well system which has been created in accordance with the invention and which comprises a main wellbore into which one or more primary sidetracks comprising an expanded expandable
20 liner debouch and one or more secondary sidetracks which debouch into the primary sidetrack or sidetracks through one or more openings in the wall of the expanded liner or liners.

It will be understood that the use of expandable
25 tubulars in a multilateral well system makes it possible that the well tubulars in the primary or mother well and in the primary and secondary sidetracks or well branches have a substantially equal internal width, so that a monobore multilateral well is created. In such a monobore
30 well system it is possible to drill tertiary sidetracks away from the secondary sidetracks, which sidetracking process can be repeated again and again so that a truly root-like multilateral well system is created.

Brief Description of the drawings

Preferred embodiments of the method and system according to the present invention will be described with reference to the drawings, in which:

5 Fig. 1 is a schematic vertical sectional view of a well system according to the invention; and

Fig. 2 is a schematic vertical sectional view of a well system according to the invention, which comprises a primary sidetrack into which two secondary sidetracks debouch.

10 Detailed Description of preferred Embodiments

Referring now to Fig. 1 there is shown a well system 1 according to the present invention which comprises a vertical main wellbore 2 which extends from a wellhead 3 at or near the earth surface 4 into a subsurface formation 5. Three primary sidetracks 6 debouch into the main wellbore 2. A secondary sidetrack 7 debouches into each primary sidetrack 6 through an opening 8 in the wall of an expanded expandable steel liner 9, of which only the section in the region of each opening 8 is shown.

20 The use of expanded liners 9 maximizes the internal width of the liners 9. Thus, if the wellbore of each sidetrack has a width of about 10 cm, the expanded liner may have an internal width of about seven to eight centimetres.

25 Such an internal width is a minimal requirement to allow a drilling assembly to be inserted into the primary sidetracks 6 which can be used to drill secondary sidetracks 7 of a sufficient width which is necessary to allow hydrocarbon fluids to flow in sufficient quantities through the secondary sidetracks 7 into the primary sidetracks.

30 Preferably also the main wellbore 2 is cased with an expandable steel casing which is cladded against the wellbore during the expansion process in a similar manner

as the expandable liners 9 have been cladded against the wellbore of the primary sidetracks 6.

This allows a further increase in the internal width of the liners 9 and of the secondary sidetracks 7.

5 The primary and secondary sidetracks 6 and 7 each extend into hydrocarbon fluid bearing formations 10 which are shown as shaded areas in the drawing.

10 It will be understood that the illustrated well system provides a root-like well configuration which provides an optimum drainage of hydrocarbon fluids from the hydrocarbon fluid bearing formations 10.

Referring now to Fig. 2 there is shown a vertical primary wellbore 20 from which a primary sidetrack 21 has been drilled away in a horizontal direction.

15 The primary sidetrack 21 is lined with an expandable steel liner 22. Preferably the liner 22 is formed by a coiled tubing which has been used during drilling to feed drilling fluid to a drill bit (not shown) and to a hydraulic downhole mud motor (not shown) which is used to rotate the drill bit.

20 After completion of drilling the coiled tubing is expanded such that it is cladded against the wellbore and subsequently serves as a steel lining of the wellbore of the primary sidetrack 21.

25 Subsequently a 4.5 inch (= about 12 cm) shoe 22 and a plug 23 are installed near the toe 24 of the primary sidetrack 21 inside the liner 22.

30 Then a whipstock 25 is inserted and anchored within the liner 22 and a hanger 26 having an internal width of about 7 cm is inserted into the expanded liner 22 which has an internal width of about 10 cm. Then a drilling assembly (not shown) is inserted through the hanger 26 and is induced by the whipstock 25 to mill an opening into the liner 22 and to subsequently drill the secondary

sidetrack 30 into a hydrocarbon fluid bearing formation 31.

5 In the example shown a conventional steel liner 31 has been inserted into the secondary sidetrack 30 which has an outer diameter of about 7 cm and which is perforated in the well inflow zone by means of a perforating gun (not shown).

10 After completion of the first secondary sidetrack 30 another whipstock 32 is inserted and anchored inside the expanded liner 22 close to the heel of the lateral primary sidetrack 21 whereupon yet another secondary sidetrack 33 is drilled and completed in the same manner as described with reference to the first secondary sidetrack 30.

15 After insertion of a steel liner 34 in the second secondary sidetrack either an opening (not shown) is drilled through the wall of the liner 34 and through the whipstock 34 or an already existing fluid passage in the whipstock and a fluid passage in the hanger 35 are used
20 to allow hydrocarbon fluid to flow from the first secondary sidetrack 30 and through the primary sidetrack 21 into the main wellbore 20.

C L A I M S

1. A method for creating a secondary sidetrack in a well system for production of hydrocarbon fluids from a hydrocarbon formation, which well system comprises a main wellbore and a primary sidetrack which debouches into the primary wellbore, the method comprising inserting an unexpanded expandable liner into the primary sidetrack and radially expanding the liner; characterized in that an opening is created in the wall of the expanded liner in the primary sidetrack; and that a secondary sidetrack is drilled into the hydrocarbon bearing formation through said opening.
2. The method according to claim 1, wherein the expandable liner is formed by a coiled tubing through which drilling fluid is pumped towards a downhole drilling assembly which is used to drill the primary sidetrack and which coiled tubing is radially expanded after the primary sidetrack has been drilled.
3. The method according to claim 1 or 2, wherein the secondary sidetrack is drilled with a drilling assembly which is connected to a coiled tubing, which tubing is expanded after the secondary sidetrack has been drilled to form a lining in the secondary sidetrack.
4. The method according to claim 1 or 2, wherein the secondary sidetrack is lined along at least part of its length with an expandable slotted liner which is expanded inside the secondary sidetrack such that a series of staggered slots in the liner open up into diamond shaped apertures.
5. The method according to claim 4, wherein an expandable sandscreen is arranged around the expandable

slotted liner in the zone where hydrocarbon fluids flow into the well system.

- 5 6. The method according to claim 1, wherein an unexpandable liner is inserted into the secondary sidetrack which liner is perforated in the zone where hydrocarbon fluids flow into the well system.
7. The method according to claim 1, wherein the capillary sidetrack is uncased along at least part of its length.
- 10 8. The method according to claim 1, wherein a plurality of primary sidetracks debouch into the primary wellbore and wherein a plurality of secondary sidetracks debouch into at least one of the primary sidetracks.
- 15 9. A well system comprising at least one primary sidetrack and at least one secondary sidetrack wherein the primary sidetrack comprises an expanded expandable liner which comprises an opening into which a secondary sidetrack debouches.
- 20 10. The well system of claim 9, wherein the expanded liner in the primary sidetrack has an internal width which is substantially equal to the internal width of a casing in the primary wellbore.
- 25 11. The well system of claim 10, wherein one or more tertiary sidetracks debouch into at least one secondary sidetrack so that a root-like multilateral well system is created.

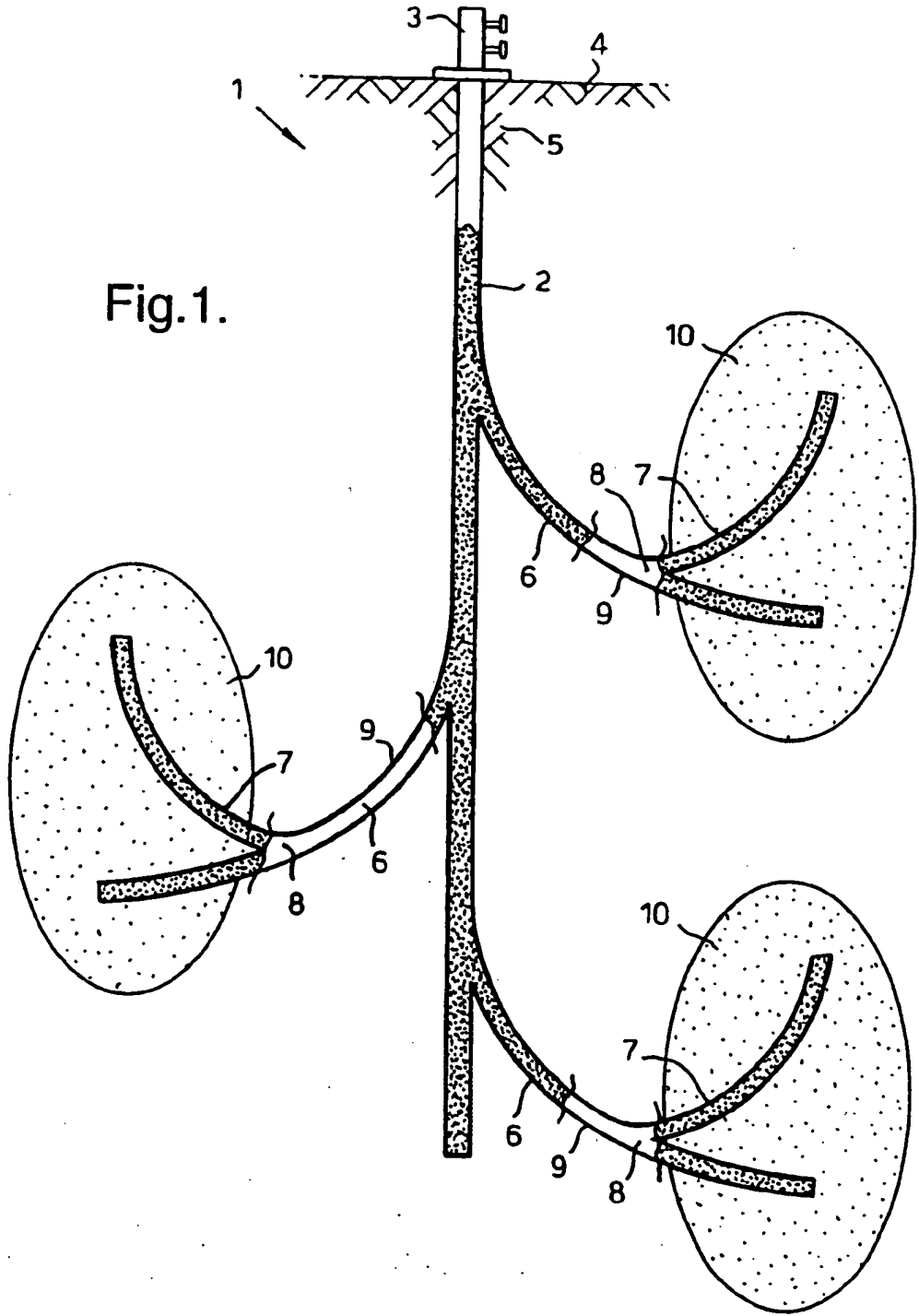

Fig. 1.

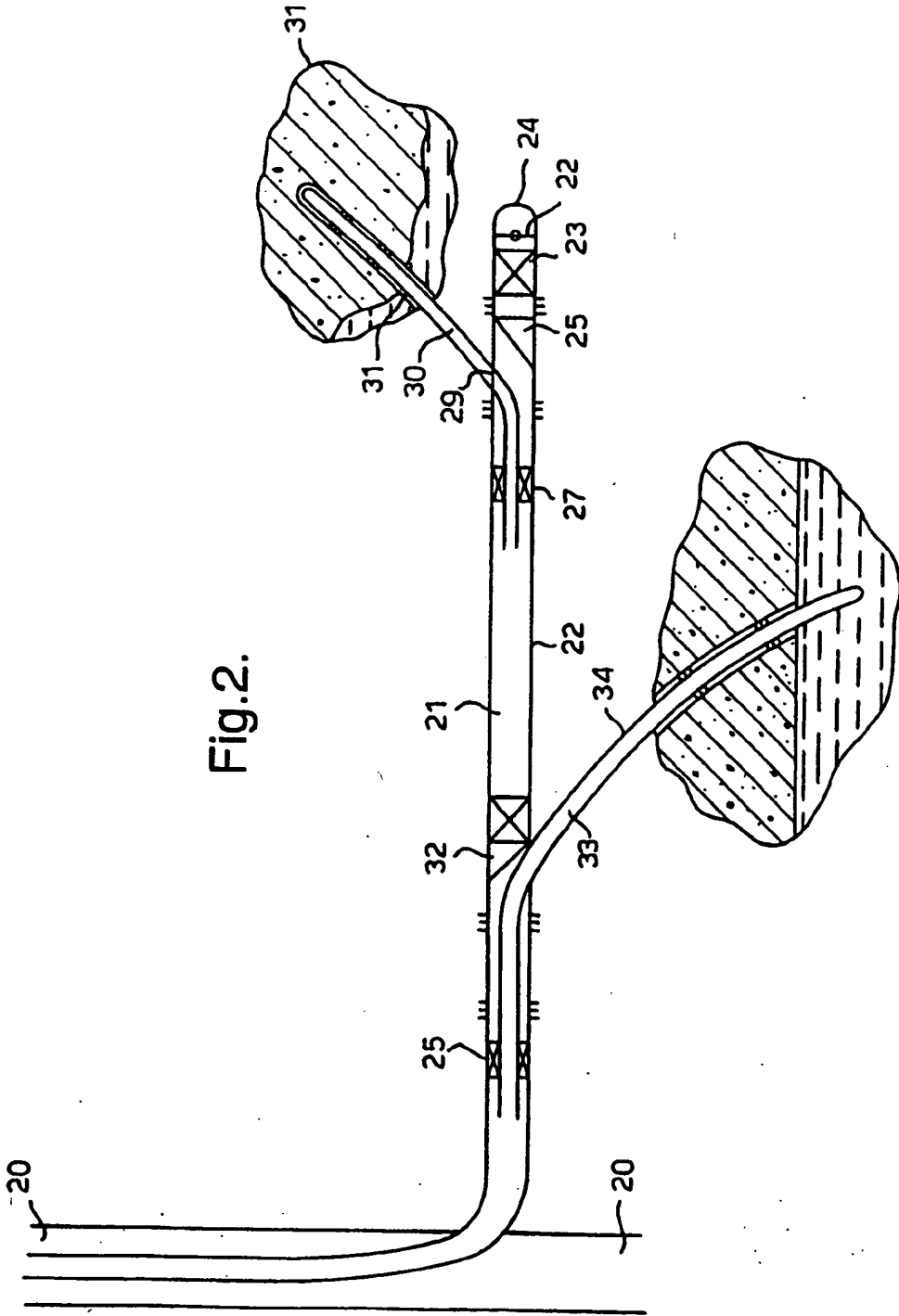

Fig. 2.

INTERNATIONAL SEARCH REPORT

International Application No.

PCT/EP 00/00791

A. CLASSIFICATION OF SUBJECT MATTER IPC 7 E21B43/10		
According to International Patent Classification (IPC) or to both national classification and IPC		
B. FIELDS SEARCHED		
Minimum documentation searched (classification system followed by classification symbols) IPC 7 E21B		
Documentation searched other than minimum documentation to the extent that such documents are included in the fields searched		
Electronic data base consulted during the international search (name of data base and, where practical, search terms used)		
C. DOCUMENTS CONSIDERED TO BE RELEVANT		
Category*	Citation of document, with indication, where appropriate, of the relevant passages	Relevant to claim No.
Y	EP 0 310 215 A (ATLANTIC RICHFIELD CO) 5 April 1989 (1989-04-05) column 8, line 2 - line 29; figure 2	1
Y	US 5 348 095 A (WORRALL ROBERT N ET AL) 20 September 1994 (1994-09-20) column 1, line 46 -column 2, line 8; figures 6,7	1,9-11
Y	"HOW MULTILATERAL BOREHOLES IMPACT ULTIMATE RECOVERY STRATEGIES" OFFSHORE, vol. 57, no. 7, 1 July 1997 (1997-07-01), page 46, 48, 80 XP000721794 figure 1	9-11
--- /---		
<input checked="" type="checkbox"/> Further documents are listed in the continuation of box C.		
<input checked="" type="checkbox"/> Patent family members are listed in annex.		
* Special categories of cited documents :		
"A" document defining the general state of the art which is not considered to be of particular relevance "E" earlier document but published on or after the international filing date "L" document which may throw doubts on priority claim(s) or which is cited to establish the publication date of another citation or other special reason (as specified) "O" document referring to an oral disclosure, use, exhibition or other means "P" document published prior to the international filing date but later than the priority date claimed "T" later document published after the international filing date or priority date and not in conflict with the application but cited to understand the principle or theory underlying the invention "X" document of particular relevance; the claimed invention cannot be considered novel or cannot be considered to involve an inventive step when the document is taken alone "Y" document of particular relevance; the claimed invention cannot be considered to involve an inventive step when the document is combined with one or more other such documents, such combination being obvious to a person skilled in the art "B" document member of the same patent family		
Date of the actual completion of the international search <div style="text-align: center; font-size: large;">20 June 2000</div>		Date of mailing of the international search report <div style="text-align: center; font-size: large;">30/06/2000</div>
Name and mailing address of the ISA European Patent Office, P.B. 5818 Patentlaan 2 NL - 2280 HV Rijswijk Tel. (+31-70) 340-2040, Tx. 31 651 apo rl, Fax: (+31-70) 340-3010		Authorized officer <div style="text-align: center; font-size: large;">Bellingacci, F</div>

Patent document cited in search report	Publication date	Patent family member(s)	Publication date
EP 0310215 A	05-04-1989	US 4807704 A	28-02-1989
		CA 1327036 A	15-02-1994
		NO 884249 A	29-03-1989
US 5348095 A	20-09-1994	AU 670948 B	08-08-1996
		AU 4324493 A	04-01-1994
		CA 2137560 A	23-12-1993
		DE 69306110 D	02-01-1997
		DE 69306110 T	05-06-1997
		DK 643794 T	05-05-1997
		WO 9325799 A	23-12-1993
		EP 0643794 A	22-03-1995
		JP 7507610 T	24-08-1995
		NO 944721 A	07-12-1994
		NZ 253124 A	27-02-1996
		SG 46560 A	20-02-1998
		WO 9800626 A	08-01-1998
BR 9710016 A	10-08-1999		
CA 2260191 A	08-01-1998		
EP 0907822 A	14-04-1999		
NO 986171 A	22-02-1999		
US 5435400 A	25-07-1995	CA 2191076 A	30-11-1995
		DE 69505523 D	26-11-1998
		DE 69505523 T	20-05-1999
		EP 0760895 A	12-03-1997
		WO 9532353 A	30-11-1995
		NO 964942 A	21-11-1996
US 5667011 A	16-09-1997	AT 179239 T	15-05-1999
		AU 685346 B	15-01-1998
		AU 4487196 A	07-08-1996
		BR 9607564 A	07-07-1998
		CA 2209224 A	25-07-1996
		CN 1174588 A	25-02-1998
		DE 69602170 D	27-05-1999
		DE 69602170 T	16-09-1999
		EG 20651 A	31-10-1999
		WO 9622452 A	25-07-1996
		EP 0804678 A	05-11-1997
		ES 2130788 T	01-07-1999
		GR 3030535 T	29-10-1999
		JP 10512636 T	02-12-1998
		NO 973280 A	15-07-1997
		NZ 300201 A	25-02-1999
		ZA 9600241 A	14-08-1996
WO 9849423 A	05-11-1998	AU 717503 B	30-03-2000
		AU 7651798 A	24-11-1998
		EP 0980462 A	23-02-2000
		NO 995248 A	27-10-1999

INTERNATIONAL SEARCH REPORT

International Application No

PCT/EP 00/00791

C. (Continuation) DOCUMENTS CONSIDERED TO BE RELEVANT

Category*	Citation of document, with indication, where appropriate, of the relevant passages	Relevant to claim No.
A	<p>METCALFE P: "EXPANDABLE SLOTTED TUBES OFFER WELL DESIGN BENEFITS" PETROLEUM ENGINEER INTERNATIONAL, vol. 69, no. 10, 1 October 1996 (1996-10-01), pages 60-63, XP000684479 figure 4</p>	1,4,8
A	<p>WO 98 00626 A (SHELL INT RESEARCH ;SHELL CANADA LTD (CA)) 8 January 1998 (1998-01-08) claims 1,15; figure 1</p>	2,3
A	<p>US 5 435 400 A (SMITH MICHAEL B) 25 July 1995 (1995-07-25) column 3, line 18 - line 25</p>	2,3
A	<p>US 5 667 011 A (GILL DALJIT SINGH ET AL) 16 September 1997 (1997-09-16) claim 1; figures 1,2</p>	4
A	<p>WO 98 49423 A (SHELL CANADA LTD ;SHELL INT RESEARCH (NL)) 5 November 1998 (1998-11-05) claim 1; figures 1-3</p>	5